



# 3V, ±15kV ESD-Protected, AutoShutdown Plus RS-232 Transceiver for PDAs and Cell Phones

MAX3387E

## General Description

The MAX3387E 3V powered TIA/EIA-232 and V.28/V.24 is a communications interface with low power requirements, high data-rate capabilities, and enhanced electrostatic discharge (ESD) protection. The MAX3387E has three receivers and three transmitters. All RS-232 inputs and outputs are protected to ±15kV using the IEC 1000-4-2 Air-Gap Discharge method, ±8kV using the IEC 1000-4-2 Contact Discharge method, and ±15kV using the Human Body Model.

A proprietary low-dropout transmitter output stage enables true RS-232 performance from a +3.0V to +5.5V supply with a dual charge pump. The charge pump requires only four small 0.1µF capacitors for operation from a +3.3V supply. The MAX3387E is capable of running at data rates up to 250kbps while maintaining RS-232 compliant output levels.

The MAX3387E has a unique V<sub>L</sub> pin that allows interoperation in mixed-logic voltage systems. Both input and output logic levels are pin programmable through the V<sub>L</sub> pin. The MAX3387E is available in a space-saving TSSOP package.

## Applications

- Subnotebook/Palmtop Computers
- PDAs and PDA Cradles
- Cell Phone Data Cables
- Battery-Powered Equipment
- Hand-Held Equipment
- Peripherals

## Pin Configuration

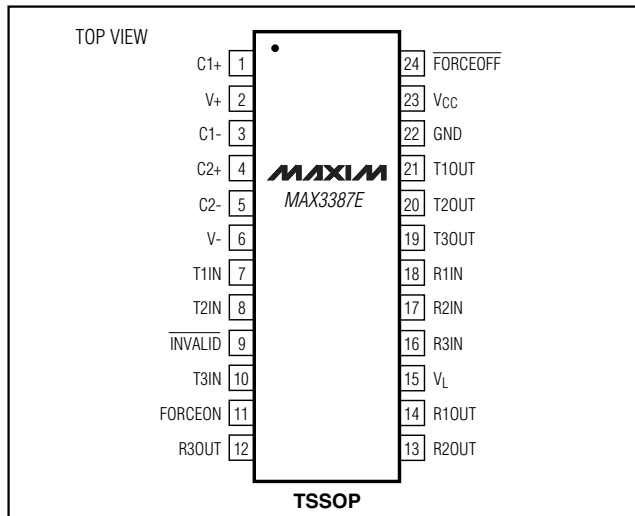

AutoShutdown Plus is a trademark of Maxim Integrated Products.

## Features

- ◆ V<sub>L</sub> Pin for Compatibility with Mixed-Voltage Systems
- ◆ ±15kV ESD Protection on Rx Inputs and Tx Outputs
- ◆ Low 300µA Supply Current
- ◆ Guaranteed 250kbps Data Rate
- ◆ 1µA AutoShutdown Plus™ with Receivers Active
- ◆ Meets TIA/EIA-232 Specifications Down to 3.0V

## Ordering Information

PART	TEMP. RANGE	PIN-PACKAGE
MAX3387EUCG	0°C to +70°C	24 TSSOP
MAX3387EEUG	-40°C to +85°C	24 TSSOP

## Typical Operating Circuit

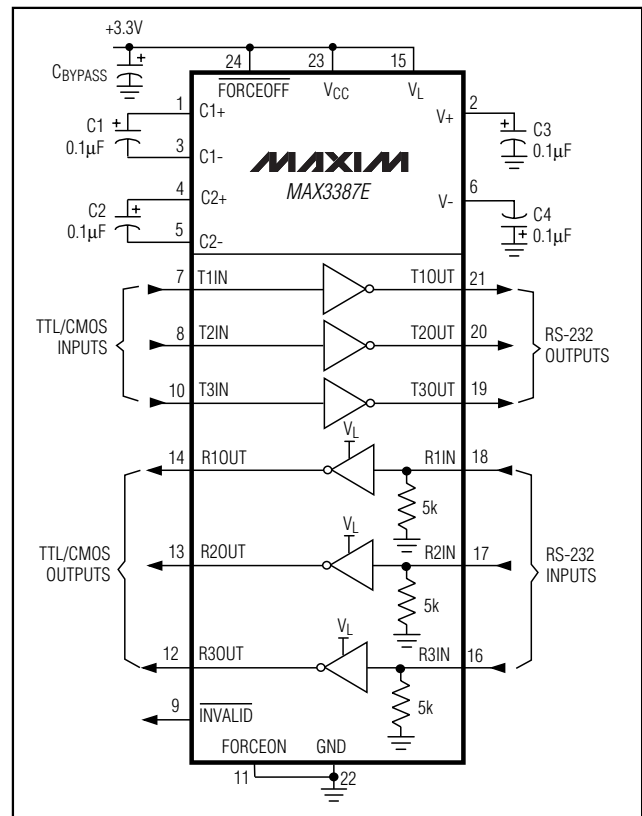

**For pricing, delivery, and ordering information, please contact Maxim/Dallas Direct! at 1-888-629-4642, or visit Maxim's website at [www.maxim-ic.com](http://www.maxim-ic.com).**

# 3V, ±15kV ESD-Protected, AutoShutdown Plus RS-232 Transceiver for PDAs and Cell Phones

## ABSOLUTE MAXIMUM RATINGS

V <sub>CC</sub> to GND .....	-0.3V to +6V	Short-Circuit Duration T <sub>OUT</sub> to GND.....	Continuous
V <sub>L</sub> to GND.....	-0.3V to (V <sub>CC</sub> + 0.3V)	Continuous Power Dissipation (T <sub>A</sub> = +70°C)	
V <sub>+</sub> to GND .....	-0.3V to +7V	24-Pin TSSOP (derate 7.8mW/°C above +70°C) .....	625mW
V <sub>-</sub> to GND .....	+0.3V to -7V	Operating Temperature Ranges	
V <sub>+</sub> +  V <sub>-</sub>   (Note 1) .....	+13V	MAX3387ECUG .....	0°C to +70°C
Input Voltages		MAX3387EEUG .....	-40°C to +85°C
T <sub>IN</sub> , FORCEON, FORCEOFF to GND .....	-0.3V to +6V	Junction Temperature .....	+150°C
R <sub>IN</sub> to GND .....	±25V	Storage Temperature Range .....	-65°C to +150°C
Output Voltages		Lead Temperature (soldering, 10s) .....	+300°C
T <sub>OUT</sub> to GND.....	±13.2V		
R <sub>OUT</sub> .....	-0.3V to (V <sub>L</sub> + 0.3V)		

**Note 1:** V<sub>+</sub> and V<sub>-</sub> can have maximum magnitudes of 7V, but their absolute difference cannot exceed 13V.

Stresses beyond those listed under "Absolute Maximum Ratings" may cause permanent damage to the device. These are stress ratings only, and functional operation of the device at these or any other conditions beyond those indicated in the operational sections of the specifications is not implied. Exposure to absolute maximum rating conditions for extended periods may affect device reliability.

## DC ELECTRICAL CHARACTERISTICS

(V<sub>CC</sub> = V<sub>L</sub> = +3.0V to +5.5V; C1–C4 = 0.1μF, tested at +3.3V ±10%; C1 = 0.047μF, C2–C4 = 0.33μF, tested at +5.0V ±10%; T<sub>A</sub> = T<sub>MIN</sub> to T<sub>MAX</sub>, unless otherwise noted. Typical values are at V<sub>CC</sub> = V<sub>L</sub> = +3.3V, T<sub>A</sub> = +25°C.)

PARAMETER	SYMBOL	CONDITIONS	MIN	TYP	MAX	UNITS
<b>DC CHARACTERISTICS</b> (V <sub>CC</sub> = +3.3V or +5V, T <sub>A</sub> = +25°C)						
Supply Current, AutoShutdown Plus		All R <sub>IN</sub> idle, FORCEON = GND, FORCEOFF = V <sub>CC</sub> , all T <sub>IN</sub> idle		1.0	10	μA
Supply Current		FORCEOFF = FORCEON = V <sub>CC</sub> , no load		0.3	1	mA
<b>LOGIC INPUTS</b>						
Input Logic Threshold Low		T <sub>IN</sub> , FORCEON, FORCEOFF	V <sub>L</sub> = 3.3V or 5.0V		0.8	V
			V <sub>L</sub> = 2.5V		0.6	
Input Logic Threshold High		T <sub>IN</sub> , FORCEON, FORCEOFF	V <sub>L</sub> = 5.0V	2.4		V
			V <sub>L</sub> = 3.3V	2.0		
			V <sub>L</sub> = 2.5V	1.4		
			V <sub>L</sub> = 1.8V	0.9		
Transmitter Input Hysteresis				0.5		V
Input Leakage Current		T <sub>IN</sub> , FORCEON, FORCEOFF		±0.01	±1	μA
<b>RECEIVER OUTPUTS</b>						
Output Voltage Low		I <sub>OUT</sub> = 1.6mA			0.4	V
Output Voltage High		I <sub>OUT</sub> = -1mA	V <sub>L</sub> - 0.6	V <sub>L</sub> - 0.1		V
<b>RECEIVER INPUTS</b>						
Input Voltage Range			-25		+25	V
Input Threshold Low		T <sub>A</sub> = +25°C	V <sub>L</sub> = 5.0V	0.8	1.5	V
			V <sub>L</sub> = 3.3V	0.6	1.2	
Input Threshold High		T <sub>A</sub> = +25°C	V <sub>L</sub> = 5.0V		1.8	2.4
			V <sub>L</sub> = 3.3V		1.5	2.4

# 3V, ±15kV ESD-Protected, AutoShutdown Plus RS-232 Transceiver for PDAs and Cell Phones

**MAX3387E**

## DC ELECTRICAL CHARACTERISTICS (continued)

(V<sub>CC</sub> = V<sub>L</sub> = +3.0V to +5.5V; C1–C4 = 0.1μF, tested at +3.3V ±10%; C1 = 0.047μF, C2–C4 = 0.33μF, tested at +5.0V ±10%; T<sub>A</sub> = T<sub>MIN</sub> to T<sub>MAX</sub>, unless otherwise noted. Typical values are at V<sub>CC</sub> = V<sub>L</sub> = +3.3V, T<sub>A</sub> = +25°C.)

PARAMETER	SYMBOL	CONDITIONS	MIN	TYP	MAX	UNITS
Input Hysteresis				0.5		V
Input Resistance		T <sub>A</sub> = +25°C	3	5	7	kΩ
<b>TRANSMITTER OUTPUTS</b>						
Output Voltage Swing		All transmitter outputs loaded with 3kΩ to ground	±5	±5.4		V
Output Resistance		V <sub>CC</sub> = V <sub>+</sub> = V <sub>-</sub> = 0, transmitter output = ±2V	300	10M		Ω
Output Short-Circuit Current		V <sub>T_OUT</sub> = 0			±60	mA
Output Leakage Current		V <sub>T_OUT</sub> = ±12V, transmitters disabled; V <sub>CC</sub> = 0 or 3.0V to 5.5V			±25	μA
<b>ESD PROTECTION</b>						
R <sub>IN</sub> , T <sub>OUT</sub> ESD Protection		Human Body Model		±15		kV
		IEC 1000-4-2 Air-Gap Discharge method		±15		
		IEC 1000-4-2 Contact Discharge method		±8		
<b>AutoShutdown Plus</b> (FORCEON = GND, FORCEOFF = V <sub>CC</sub> )						
Receiver Input Threshold to $\overline{\text{INVALID}}$ Output High		Figure 3a	Positive threshold		2.7	V
			Negative threshold	-2.7		
Receiver Input Threshold to $\overline{\text{INVALID}}$ Output Low		Figure 3a	-0.3		0.3	V
$\overline{\text{INVALID}}$ Output Voltage Low		I <sub>OUT</sub> = -1.6mA			0.4	V
$\overline{\text{INVALID}}$ Output Voltage High		I <sub>OUT</sub> = -1.0mA	V <sub>L</sub> - 0.6			V
Receiver Positive or Negative Threshold to $\overline{\text{INVALID}}$ High	t <sub>INVH</sub>	V <sub>CC</sub> = 5V, Figure 3b		1		μs
Receiver Positive or Negative Threshold to $\overline{\text{INVALID}}$ Low	t <sub>INVL</sub>	V <sub>CC</sub> = 5V, Figure 3b		30		μs
Receiver or Transmitter Edge to Transmitters Enabled	t <sub>WU</sub>	V <sub>CC</sub> = 5V, Figure 3b		100		μs
Receiver or Transmitter Edge to Transmitters Shutdown	t <sub>AUTOSHDN</sub>	V <sub>CC</sub> = 5V, Figure 3b	15	30	60	s

# 3V, ±15kV ESD-Protected, AutoShutdown Plus RS-232 Transceiver for PDAs and Cell Phones

## TIMING CHARACTERISTICS

( $V_{CC} = V_L = +3V$  to  $+5.5V$ ;  $C1-C4 = 0.1\mu F$ , tested at  $+3.3V \pm 10\%$ ;  $C1 = 0.047\mu F$ ,  $C2-C4 = 0.33\mu F$ , tested at  $+5.0V \pm 10\%$ ;  $T_A = T_{MIN}$  to  $T_{MAX}$ , unless otherwise noted. Typical values are at  $V_{CC} = V_L = +3.3V$ ,  $T_A = +25^\circ C$ .)

PARAMETER	SYMBOL	CONDITIONS		MIN	TYP	MAX	UNITS
Maximum Data Rate		$R_L = 3k\Omega$ , $C_L = 1000pF$ , one transmitter switching		250			kbps
Receiver Propagation Delay	$t_{PHL}$	Receiver input to receiver output, $C_L = 150pF$			0.15		$\mu s$
	$t_{PLH}$				0.15		
Time to Exit Shutdown		$ V_{T\_OUT}  > 3.7V$			100		$\mu s$
Transmitter Skew	$ t_{PHL} - t_{PLH} $	(Note 2)			100		ns
Receiver Skew	$ t_{PHL} - t_{PLH} $				50		ns
Transition-Region Slew Rate		$V_{CC} = 3.3V$ , $T_A = +25^\circ C$ , $R_L = 3k\Omega$ to $7k\Omega$ , measured from $+3V$ to $-3V$ or $-3V$ to $+3V$	$C_L = 150pF$ to $1000pF$	6		30	$V/\mu s$
			$C_L = 150pF$ to $2500pF$	4		30	

# 3V, ±15kV ESD-Protected, AutoShutdown Plus RS-232 Transceiver for PDAs and Cell Phones

## Typical Operating Characteristics

( $V_{CC} = V_L = +3.3V$ ,  $T_A = +25^\circ C$ , unless otherwise noted.)

**MAX3387E**

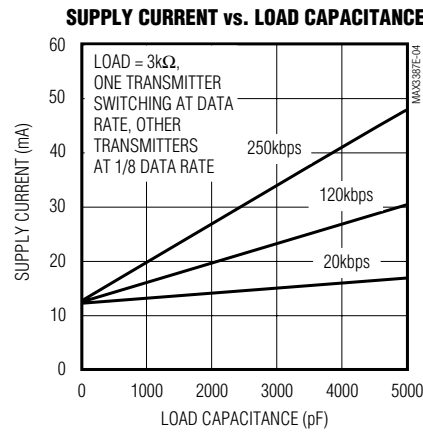
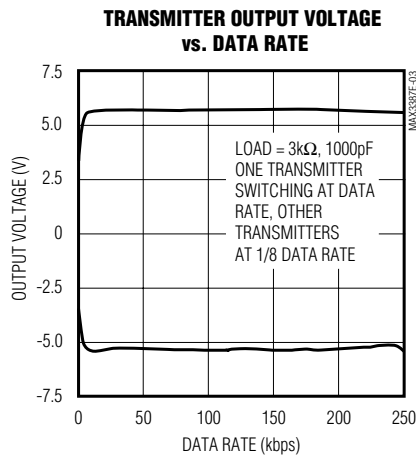
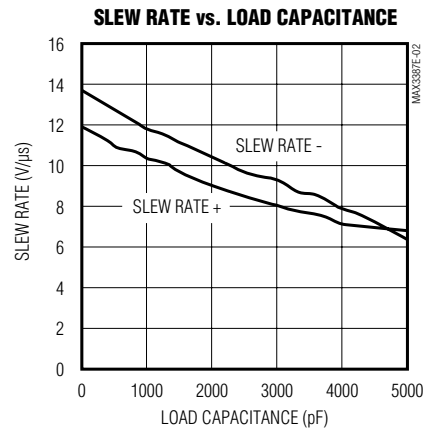
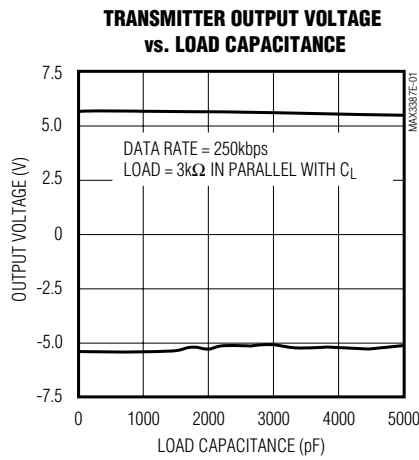

# 3V, ±15kV ESD-Protected, AutoShutdown Plus RS-232 Transceiver for PDAs and Cell Phones

## Pin Description

PIN	NAME	FUNCTION
1	C1+	Positive Terminal of the Voltage-Doubler Charge-Pump Capacitor
2	V+	+5.5V Supply Generated by the Charge Pump
3	C1-	Negative Terminal of the Voltage-Doubler Charge-Pump Capacitor
4	C2+	Positive Terminal of the Inverting Charge-Pump Capacitor
5	C2-	Negative Terminal of the Inverting Charge-Pump Capacitor
6	V-	-5.5V Generated by the Charge Pump
7	T1IN	TTL/CMOS Transmitter Inputs
8	T2IN	
9	$\overline{\text{INVALID}}$	Output of the Valid Signal Detector. $\overline{\text{INVALID}}$ is high if a valid RS-232 signal is present on the receiver inputs.
10	T3IN	TTL/CMOS Transmitter Inputs
11	FORCEON	Force-On Input. Drive high to override automatic circuitry keeping transmitters on (FORCEOFF must be high) (Table 1).
12	R3OUT	TTL/CMOS Receiver Outputs. Swing between 0 and $V_L$ .
13	R2OUT	
14	R1OUT	
15	$V_L$	Logic-Level Supply. All CMOS inputs and outputs are referenced to this supply.
16	R3IN	RS-232 Receiver Inputs
17	R2IN	
18	R1IN	
19	T3OUT	RS-232 Transmitter Outputs
20	T2OUT	
21	T1OUT	
22	GND	Ground
23	$V_{CC}$	+3.0V to +5.5V Supply Voltage
24	$\overline{\text{FORCEOFF}}$	Force-Off Input. Drive low to shut down transmitters and on-board power supply. This overrides all automatic circuitry and FORCEON (Table 1).

# 3V, ±15kV ESD-Protected, AutoShutdown Plus RS-232 Transceiver for PDAs and Cell Phones

MAX3387E

## Detailed Description

### Dual Charge-Pump Voltage Converter

The MAX3387E's internal power supply consists of a regulated dual charge pump that provides output voltages of +5.5V (doubling charge pump) and -5.5V (inverting charge pump), regardless of the input voltage ( $V_{CC}$ ) over a +3.0V to +5.5V range. The charge pumps operate in a discontinuous mode: if the output voltages are less than 5.5V, the charge pumps are enabled; if the output voltages exceed 5.5V, the charge pumps are disabled. Each charge pump requires a flying capacitor (C1, C2) and a reservoir capacitor (C3, C4) to generate the  $V+$  and  $V-$  supplies.

### RS-232 Transmitters

The transmitters are inverting level translators that convert CMOS-logic levels to 5.0V EIA/TIA-232 levels.

The MAX3387E transmitters guarantee a 250kbps data rate with worst-case loads of  $3k\Omega$  in parallel with 1000pF, providing compatibility with PC-to-PC communication software (such as LapLink™). Transmitters can be paralleled to drive multiple receivers or mice. Figure 1 shows a complete system connection.

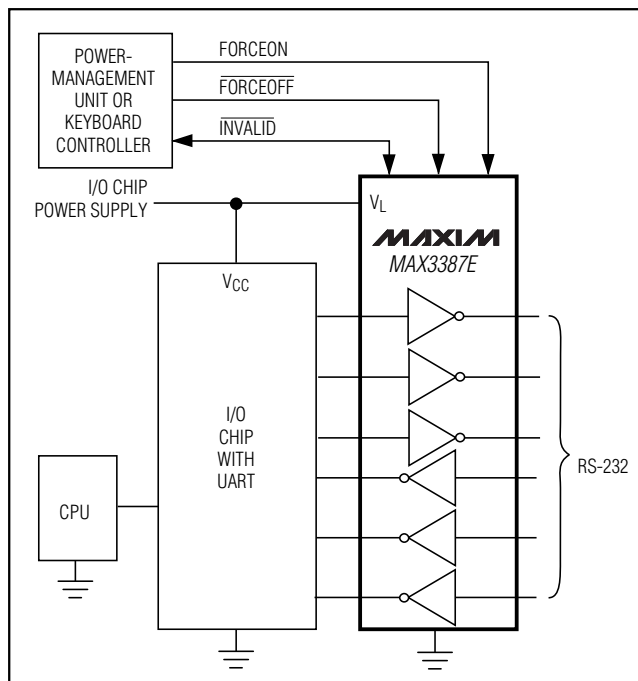

Figure 1. Interface Under Control of PMU

LapLink is a trademark of Traveling Software.

These RS-232 output stages are turned off (high impedance) when the device is in shutdown mode. When the power is off, the MAX3387E permits the outputs to be driven up to  $\pm 12V$ .

The transmitter inputs do not have pull-up resistors. Connect unused inputs to GND or  $V_L$ .

### RS-232 Receivers

The receivers convert RS-232 signals to CMOS-logic output levels. The MAX3387E's receivers are always active, even when the device is in shutdown.

The MAX3387E features an  $\overline{INVALID}$  output that indicates when no signal is present on any RS-232 receiver inputs.  $\overline{INVALID}$  is independent of other control logic functions; it indicates the receiver input conditions only (Figures 2 and 3).

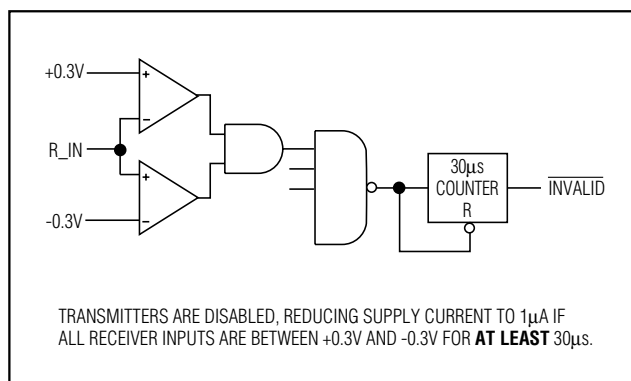

Figure 2a.  $\overline{INVALID}$  Function Diagram,  $\overline{INVALID} = Low$

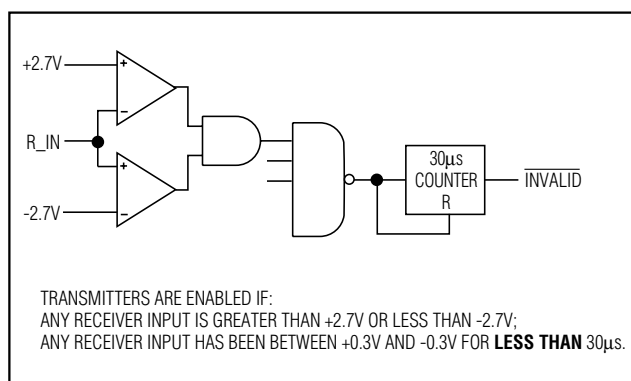

Figure 2b.  $\overline{INVALID}$  Function Diagram,  $\overline{INVALID} = High$

# 3V, ±15kV ESD-Protected, AutoShutdown Plus RS-232 Transceiver for PDAs and Cell Phones

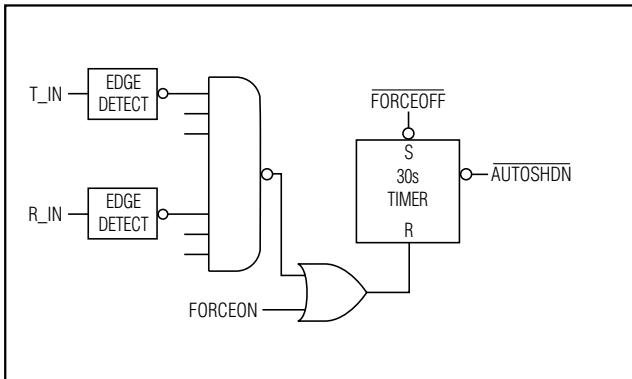

Figure 2c. AutoShutdown Plus Logic

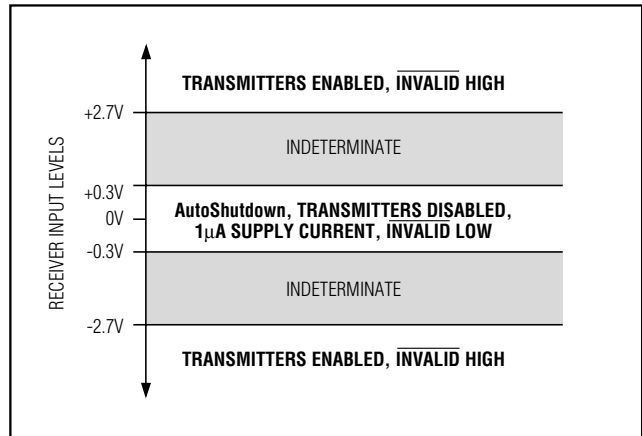

Figure 3a. Receiver Thresholds for  $\overline{\text{INVALID}}$

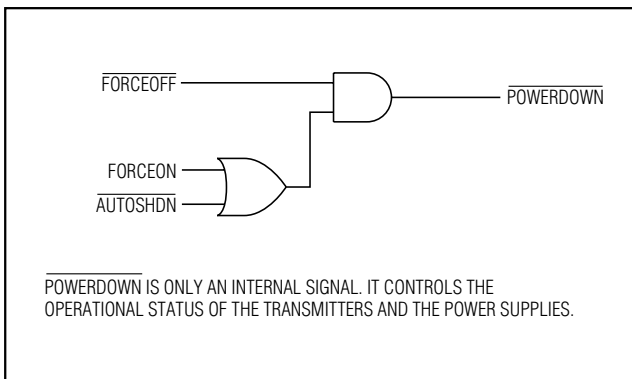

Figure 2d. Power-Down Logic

### AutoShutdown Plus Mode

The MAX3387E achieves a  $1\mu\text{A}$  supply current with Maxim's AutoShutdown Plus feature, which operates when  $\overline{\text{FORCEOFF}}$  is high and a  $\overline{\text{FORCEON}}$  is low. When these devices do not sense a valid signal transition on any receiver and transmitter input for 30sec, the on-board charge pumps are shut down, reducing supply current to  $1\mu\text{A}$ . This occurs if the RS-232 cable is disconnected or if the connected peripheral transmitters are turned off, and if the UART driving the transmitter inputs is inactive. The system turns on again when a valid transition is applied to any RS-232 receiver or transmitter input. As a result, the system saves power without changes to the existing BIOS or operating system.

Figures 2a and 2b show valid and invalid RS-232 receiver voltage levels.  $\overline{\text{INVALID}}$  indicates the receiver input's condition, and is independent of  $\overline{\text{FORCEON}}$  and

$\overline{\text{FORCEOFF}}$  states. Figure 2 and Table 1 summarize the MAX3387E's operating modes.  $\overline{\text{FORCEON}}$  and  $\overline{\text{FORCEOFF}}$  override AutoShutdown Plus circuitry. When neither control is asserted, the IC selects between these states automatically based on the last receiver or transmitter input edge received.

By connecting  $\overline{\text{FORCEON}}$  to  $\overline{\text{INVALID}}$ , the MAX3387E shuts down when no valid receiver level and no receiver or transmitter edge is detected for 30sec, and wakes up when a valid receiver level or receiver or transmitter edge is detected.

By connecting  $\overline{\text{FORCEON}}$  and  $\overline{\text{FORCEOFF}}$  to  $\overline{\text{INVALID}}$ , the MAX3387E shuts down when no valid receiver level is detected.

A mouse or other system with AutoShutdown Plus may need time to wake up. Figure 4 shows a circuit that forces the transmitters on for 100ms, allowing enough time for the other system to realize that the MAX3387E is awake. If the other system outputs valid RS-232 signal transitions within that time, the RS-232 ports on both systems remain enabled.

### $V_L$ Logic Supply Input

Unlike other RS-232 interface devices where the receiver outputs swing between 0 and  $V_{CC}$ , the MAX3387E features a separate logic supply input ( $V_L$ ) that sets  $V_{OH}$  for the receiver outputs and sets thresholds for the receiver inputs. This feature allows a great deal of flexibility in interfacing to many different types of systems with different logic levels. Connect this input to the host logic supply ( $1.8\text{V} \leq V_L \leq V_{CC}$ ). Also, see the *Typical PDA/Cell-Phone Application* section.



# 3V, ±15kV ESD-Protected, AutoShutdown Plus RS-232 Transceiver for PDAs and Cell Phones

**MAX3387E**

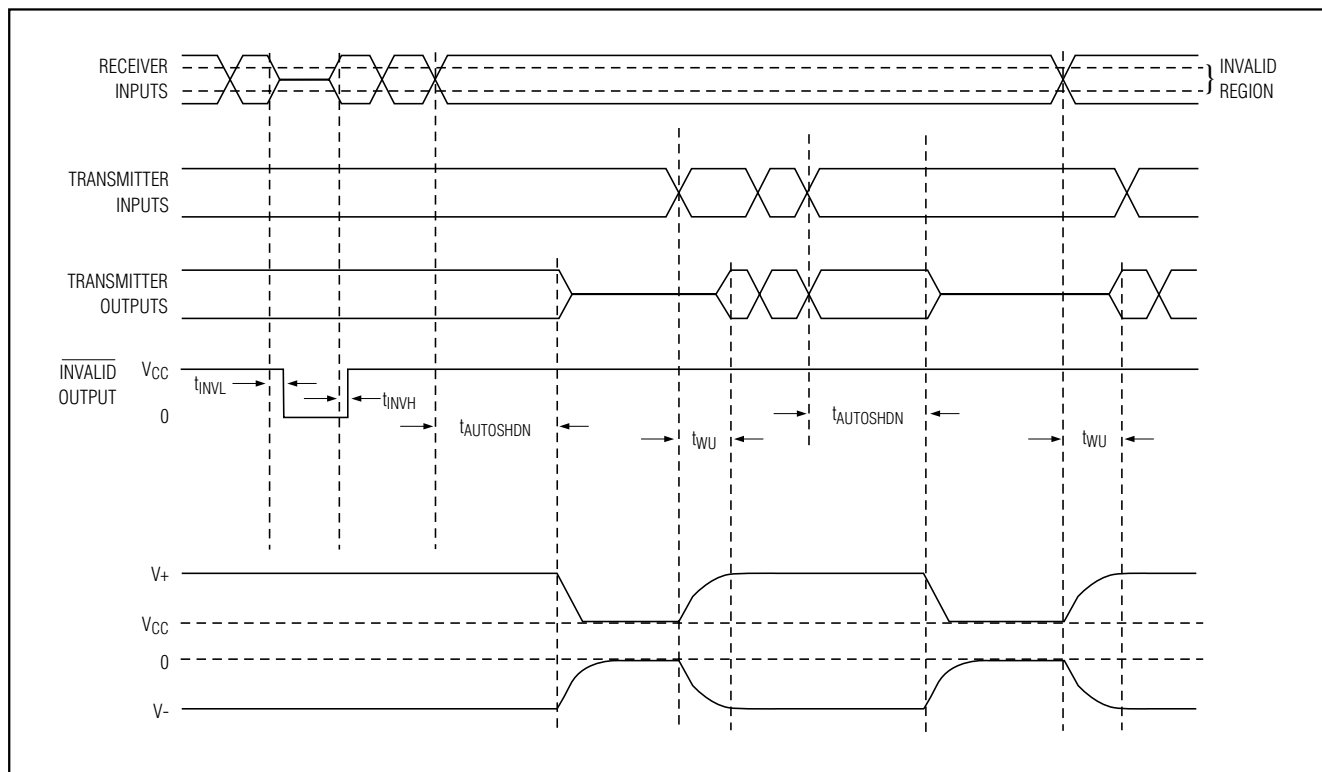

Figure 3b. AutoShutdown Plus/ $\overline{\text{INVALID}}$  Timing Diagram

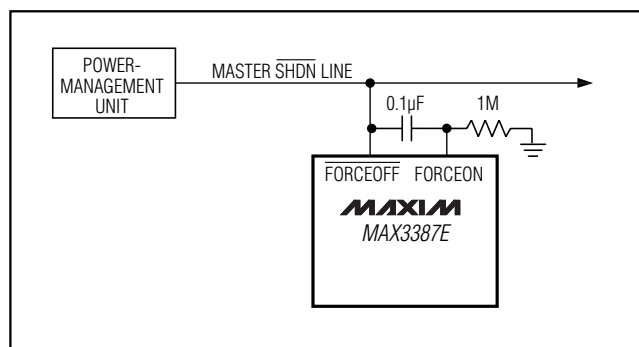

Figure 4. AutoShutdown with Initial Turn-On to Wake Up a System

## Software-Controlled Shutdown

If direct software control is desired,  $\overline{\text{INVALID}}$  can be used to indicate a DTR or ring indicator signal. Connect  $\overline{\text{FORCEOFF}}$  and  $\overline{\text{FORCEON}}$  together to bypass AutoShutdown so the line acts like a SHDN input.

## ±15kV ESD Protection

As with all Maxim devices, ESD-protection structures are incorporated on all pins to protect against electrostatic discharges (ESDs) encountered during handling and assembly. The MAX3387E driver outputs and receiver inputs have extra protection against static electricity. Maxim has developed state-of-the-art structures to protect these pins against ESD of ±15kV without damage. The ESD structures withstand high ESD in all states: normal operation, shutdown, and powered down. After an ESD event, Maxim's "E" version devices keep working without latchup, whereas competing RS-232 products can latch and must be powered down to remove latchup. ESD protection can be tested in various ways. The transmitter outputs and receiver inputs of this product family are characterized for protection to the following limits:

- 1) ±15kV using the Human Body Model
- 2) ±8kV using the Contact-Discharge method specified in IEC 1000-4-2
- 3) ±15kV using IEC 1000-4-2's Air-Gap method

# 3V, ±15kV ESD-Protected, AutoShutdown Plus RS-232 Transceiver for PDAs and Cell Phones

**Table 1. Output Control Truth Table**

OPERATION STATUS	FORCEON	$\overline{\text{FORCEOFF}}$	VALID RECEIVER LEVEL	RECEIVER OR TRANSMITTER EDGE WITHIN 30	T_OUT	R_OUT
Shutdown (Forced Off)	X	0	X	X	High-Z	Active
Normal Operation (Forced On)	1	1	X	X	Active	Active
Normal Operation (AutoShutdown Plus)	0	1	X	Yes	Active	Active
Shutdown (AutoShutdown Plus)	0	1	X	No	High-Z	Active
Normal Operation	$\overline{\text{INVALID}}$	1	Yes	X	Active	Active
Normal Operation	$\overline{\text{INVALID}}$	1	X	Yes	Active	Active
Shutdown	$\overline{\text{INVALID}}$	1	No	No	High-Z	Active
Normal Operation (AutoShutdown)	$\overline{\text{INVALID}}$	$\overline{\text{INVALID}}$	Yes	X	Active	Active
Shutdown (AutoShutdown)	$\overline{\text{INVALID}}$	$\overline{\text{INVALID}}$	No	X	High-Z	Active

X = Don't care

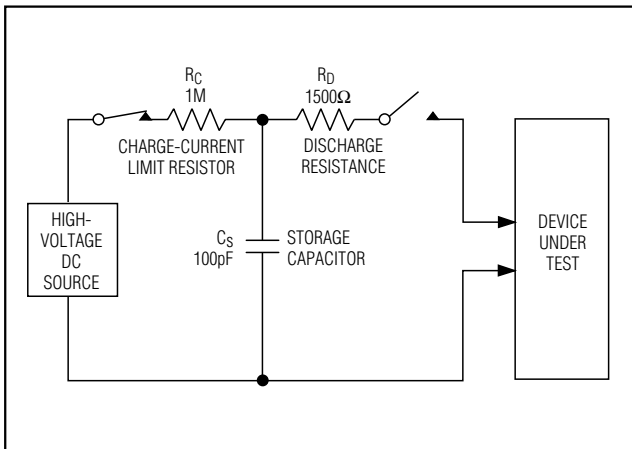

Figure 5a. Human Body ESD Test Model

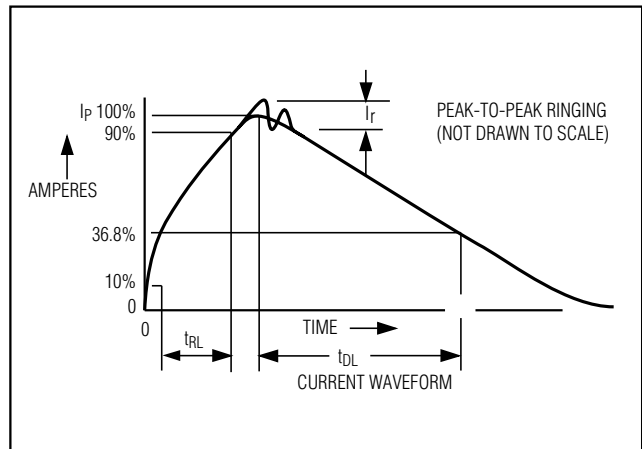

Figure 5b. Human Body Current Waveform

### ESD Test Conditions

ESD performance depends on a variety of conditions. Contact Maxim for a reliability report that documents test setup, methodology, and results.

### Human Body Model

Figure 5a shows the Human Body Model, and Figure 5b shows the current waveform it generates when discharged into a low impedance. This model consists of a 100pF capacitor charged to the ESD voltage of interest, which is then discharged into the test device through a 1.5kΩ resistor.

# 3V, ±15kV ESD-Protected, AutoShutdown Plus RS-232 Transceiver for PDAs and Cell Phones

MAX3387E

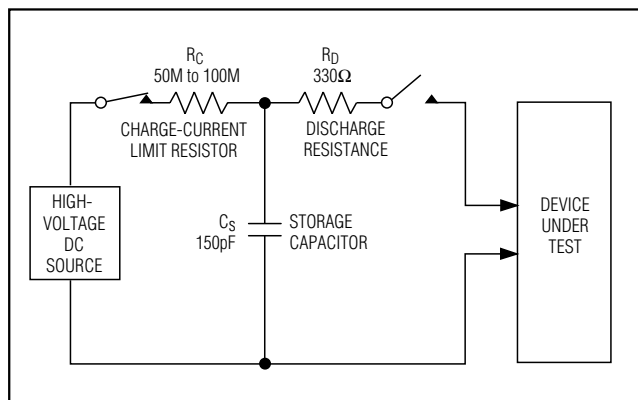

Figure 6a. IEC 1000-4-2 ESD Test Model

## IEC 1000-4-2

The IEC 1000-4-2 standard covers ESD testing and performance of finished equipment; it does not specifically refer to ICs. The MAX3387E helps you design equipment that meets Level 4 (the highest level) of IEC 1000-4-2, without the need for additional ESD-protection components.

The major difference between tests done using the Human Body Model and IEC 1000-4-2 is higher peak current in IEC 1000-4-2 because series resistance is lower in the IEC 1000-4-2 model. Hence, the ESD withstand voltage measured to IEC 1000-4-2 is generally lower than that measured using the Human Body Model. Figure 6a shows the IEC 1000-4-2 model, and Figure 6b shows the current waveform for the ±8kV IEC 1000-4-2 Level 4 ESD Contact Discharge test.

The air-gap test involves approaching the device with a charged probe. The contact-discharge method connects the probe to the device before the probe is energized.

## Machine Model

The Machine Model for ESD tests all pins using a 200pF storage capacitor and zero discharge resistance. Its objective is to emulate the stress caused by contact that occurs with handling and assembly during manufacturing. All pins require this protection during manufacturing, not just RS-232 inputs and outputs. Therefore, after PC board assembly, the Machine Model is less relevant to I/O ports.

## Applications Information

### Capacitor Selection

The capacitor type used for C1–C4 is not critical for proper operation; polarized or nonpolarized capacitors can be used. The charge pump requires 0.1µF capaci-

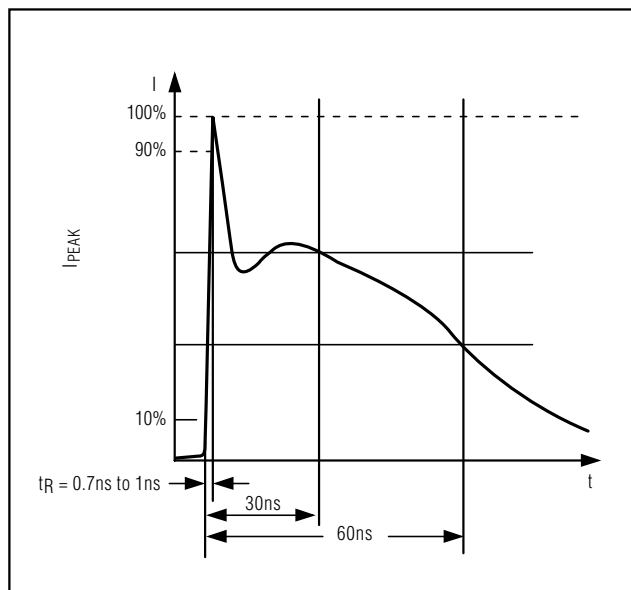

Figure 6b. IEC 1000-4-2 ESD Generator Current Waveform

**Table 2. Minimum Required Capacitor Values**

V <sub>CC</sub> (V)	C1 (µF)	C2, C3, C4 (µF)
3.0 to 3.6	0.1	0.1
4.5 to 5.5	0.047	0.33
3.0 to 5.5	0.22	1

tors for 3.3V operation. For other supply voltages, see Table 2 for required capacitor values. Do not use values smaller than those listed in Table 2. Increasing the capacitor values (e.g., by a factor of 2) reduces ripple on the transmitter outputs and slightly reduces power consumption. C2, C3, and C4 can be increased without changing C1's value. However, do not increase C1 without also increasing the values of C2, C3, and C4 to maintain the proper ratios (C1 to the other capacitors).

When using the minimum required capacitor values, make sure the capacitor value does not degrade excessively with temperature. If in doubt, use capacitors with a larger nominal value. The capacitor's equivalent series resistance (ESR), which usually rises at low temperatures, influences the amount of ripple on V<sub>+</sub> and V<sub>-</sub>.

# 3V, ±15kV ESD-Protected, AutoShutdown Plus RS-232 Transceiver for PDAs and Cell Phones

## Power-Supply Decoupling

In most circumstances, a 0.1µF bypass capacitor is adequate. In applications that are sensitive to power-supply noise, decouple VCC to ground with a capacitor of the same value as charge-pump capacitor C1. Connect bypass capacitors as close to the IC as possible.

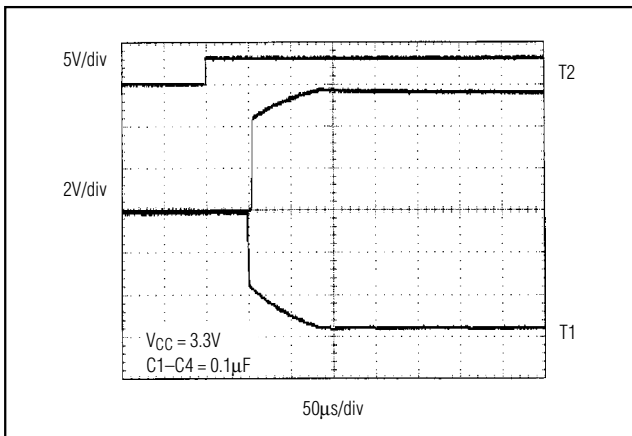

Figure 7. Transmitter Outputs when Exiting Shutdown

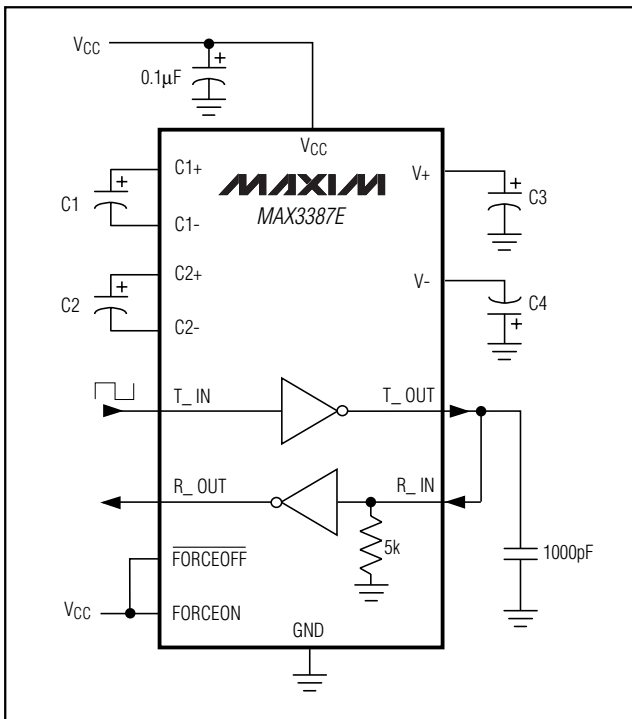

Figure 8. Loopback Test Circuit

## Operation Down to 2.7V

Transmitter outputs will meet TIA/EIA-562 levels of ±3.7V with supply voltages as low as +2.7V.

## Transmitter Outputs when Exiting Shutdown

Figure 7 shows two transmitter outputs when exiting shutdown mode. As they become active, the two transmitter outputs are shown going to opposite RS-232 levels (one transmitter input is high; the other is low). Each transmitter is loaded with 3kΩ in parallel with 2500pF. The transmitter outputs display no ringing or undesirable transients as they come out of shutdown. Note that the transmitters are enabled only when the magnitude of V- exceeds approximately 3V.

## High Data Rates

The MAX3387E maintains the RS-232 ±5.0V minimum transmitter output voltage even at high data rates. Figure 8 shows a transmitter loopback test circuit. Figure 9 shows a loopback test result at 120kbps, and Figure 10 shows the same test at 250kbps. For Figure 9, all transmitters were driven simultaneously at 120kbps into RS-232 loads in parallel with 1000pF. For Figure 10, a single transmitter was driven at 250kbps, and all transmitters were loaded with an RS-232 receiver in parallel with 1000pF.

## Interconnection with 3V and 5V Logic

The MAX3387E can directly interface with various 5V logic families, including ACT and HCT CMOS. The logic voltage power-supply pin (VL) sets the output voltage level of the receivers and the input thresholds of the transmitters.

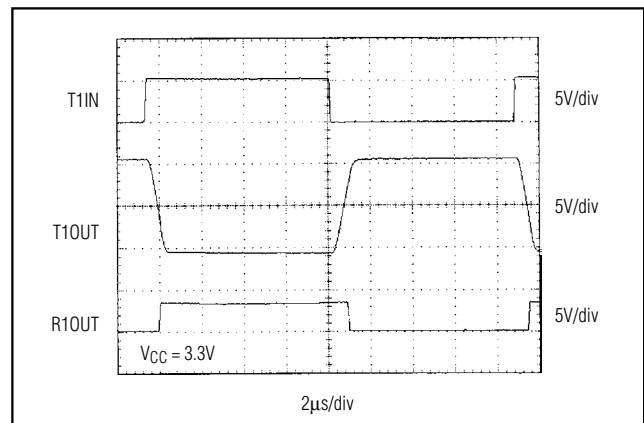

Figure 9. Loopback Test Results at 120kbps

# 3V, ±15kV ESD-Protected, AutoShutdown Plus RS-232 Transceiver for PDAs and Cell Phones

MAX3387E

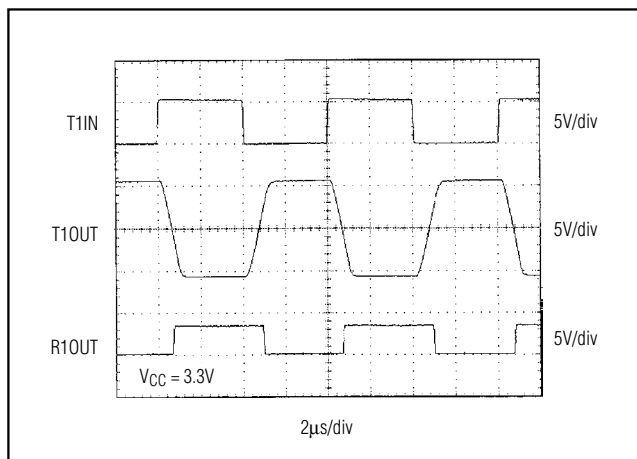

Figure 10. Loopback Test Results at 250kbps

## Typical PDA/Cell-Phone Application

The MAX3387E is designed with PDA applications in mind. Two transmitters and two receivers handle standard full-duplex communication protocol, while an extra transmitter allows a ring indicator signal to alert the UART on the PC. Without the ring indicator transmitter, solutions for these applications would require software-intensive polling of the cradle inputs.

The ring indicate (RI) signal is generated when a PDA, phone, or other “cradled” device is plugged into its cradle. This generates a logic-low signal to the RI transmitter input, creating +6V at the ring indicate pin. The PC’s UART RI input is the only pin that can generate an interrupt from signals arriving through the RS-232 port. The interrupt routine for this UART will then service the RS-232 full-duplex communication between the PDA and the PC.

As cell phone design becomes more like that of PDAs, cell phones will require similar docking ability and communication protocol. Cell phones operate on a single lithium-ion (Li+) battery and work with a power-supply voltage of +2.7V to +4V. The baseband logic coming from the phone connector can be as low as 1.8V at the transceivers. To prevent forward biasing of a device internal to the cell phone, the MAX3387E comes with a logic power-supply pin ( $V_L$ ) that limits the logic levels presented to the phone. The receiver outputs will sink to zero for low outputs, but will not exceed  $V_L$  for logic highs. The input logic levels for the transmitters are also altered, scaled by the magnitude of the  $V_L$  input. The device will work with  $V_L$  as low as 1.8V before the charge-pump noise will begin to cause the transmitter outputs to oscillate. This is useful with cell phones and other power-efficient devices with core logic voltage levels that go as low as 1.8V.

## Chip Information

TRANSISTOR COUNT: 1267

# 3V, ±15kV ESD-Protected, AutoShutdown Plus RS-232 Transceiver for PDAs and Cell Phones

## Package Information

**COMMON DIMENSIONS**

DIMENSION	MILLIMETERS		INCHES	
	MIN.	MAX.	MIN.	MAX.
A	—	1.10	—	.043
A <sub>1</sub>	0.05	0.15	.002	.006
A <sub>2</sub>	0.85	0.95	.033	.037
b	0.19	0.30	.007	.012
b <sub>1</sub>	0.19	0.25	.007	.010
c	0.090	0.20	.0035	.008
c <sub>1</sub>	0.090	0.135	.0035	.0053
D	SEE VARIATIONS		SEE VARIATIONS	
E	4.30	4.50	.169	.177
e	0.65 BSC		.026 BSC	
H	6.25	6.50	.246	.256
L	0.50	0.70	.020	.028
N	SEE VARIATIONS		SEE VARIATIONS	
Y	2.85	3.15	.112	.124
α	0°	8°	0°	8°

JEDEC	N	VARIATIONS				
		MILLIMETERS		INCHES		
		MIN.	MAX.	MIN.	MAX.	
AB	14	D	4.90	5.10	.193	.201
AC	16	D	4.90	5.10	.193	.201
AC-EP	16	D	4.90	5.10	.193	.201
		X	2.85	3.15	.112	.124
AD	20	D	6.40	6.60	.252	.260
AD-EP	20	D	6.40	6.60	.252	.260
		X	4.00	4.34	.157	.171
AE	24	D	7.70	7.90	.303	.311
AF	28	D	9.60	9.80	.378	.386
AF-EP	28	D	9.60	9.80	.378	.386
		X	5.35	5.65	.211	.222

**NOTES:**

- DIMENSIONS D AND E DO NOT INCLUDE FLASH.
- MOLD FLASH OR PROTRUSIONS NOT TO EXCEED .15 mm PER SIDE.
- CONTROLLING DIMENSION: MILLIMETER.
- MEETS JEDEC OUTLINE MO-153 VARIATIONS AB, AC, AD, AE, AF.
- DIMENSIONS X AND Y APPLY TO EXPOSED PAD (EP) VERSIONS ONLY.
- EXPOSED PAD FLUSH WITH BOTTOM OF PACKAGE WITHIN .002".

TSSOP:EPS

Maxim cannot assume responsibility for use of any circuitry other than circuitry entirely embodied in a Maxim product. No circuit patent licenses are implied. Maxim reserves the right to change the circuitry and specifications without notice at any time.

14 Maxim Integrated Products, 120 San Gabriel Drive, Sunnyvale, CA 94086 408-737-7600